



Electrolux

Modular Cooking Range Line 700XP Freestanding Gas Pasta Cooker, 1 Well 24.5 litres

ITEM # _____

MODEL # _____

NAME # _____

SIS # _____

AIA # _____



Electrolux



Modular Cooking Range Line 700XP Freestanding Gas Pasta Cooker, 1 Well 24.5 litres

371090 (E7PCGD1KF0) 24,5-lt gas pasta cooker with
1 well

Short Form Specification

Item No. _____

High efficiency 10.5 kW burners. Suitable for natural gas or LPG. Constant starch removal during the cooking process. The tank is pressed in AISI 316 stainless steel to protect against corrosion. Control panel with gas cock, piezo ignition. Manual water tap. Height adjustable feet in stainless steel. Exterior panels in stainless steel with Scotch Brite finish. One piece pressed work top in 1.5 mm thick stainless steel. Right-angled side edges to allow flush-fitting junction between units.

Main Features

- In addition to cooking pasta, the appliance can be used for noodles of every kind, rice, dumplings and vegetables.
- High efficiency 10.5 kW burners in stainless steel with flame failure device and optimized combustion, located below the well.
- No electrical connection needed.
- Water basin in 316 type Stainless steel.
- Water basin is seamlessly welded into the top of the appliance.
- Provided with integrated drip tray on which baskets can be placed for draining purposes.
- 24.5 liters water basin.
- Unit to feature skimming zone for starch removal: improved water quality over time.
- Easy-to-use control panel with gas cock and piezo ignition.
- Safety thermostat to avoid operation without water.
- Continuous water filling regulated through a manual water tap.
- Large drain with manual ball-valve for fast emptying of well.
- **ESD** available as accessory (installed separately): energy saving device uses heat produced by water drained through the overflow to pre-heat tap-in water up to 60°C, for constant water boiling.
- **EnergyControl**: unique feature for fine power adjustment to control boiling level and optimize energy consumption.
- **Automatic lifting system** (optional accessory): 200mm wide unit with two stainless steel basket supports, holding one GN 1/2 basket each, to be placed on either or both sides of machine to provide automatic lifting for four small portion baskets (to be ordered separately). Possibility to memorize nine cooking times through digital control.
- All major compartments located in front of unit for ease of maintenance.
- IPX4 water resistance certification.
- Unit delivered with four 50 mm legs in stainless steel as standard (all round Stainless steel kick plates as option).

Construction

- All exterior panels in Stainless Steel with Scotch Brite finishing.
- One piece pressed 1.5 mm work top in Stainless steel.
- Model has right-angled side edges to allow flush fitting joints between units, eliminating gaps and possible dirt traps.

Included Accessories

- 1 of Door for open base cupboard PNC 206350

Optional Accessories

- Draught diverter, 120 mm diameter PNC 206126
- Matching ring for flue condenser, 120 mm diameter PNC 206127
- 4 wheels, 2 swivelling with brake (700/900XP). It is mandatory to install with base supports for feet/wheels. PNC 206135
- Flanged feet kit PNC 206136

APPROVAL: _____



Electrolux

Modular Cooking Range Line 700XP Freestanding Gas Pasta Cooker, 1 Well 24.5 litres

- Frontal kicking strip for concrete installation, 200mm PNC 206146
- Frontal kicking strip for concrete installation, 400mm PNC 206147
- Frontal kicking strip for concrete installation, 800mm PNC 206148
- Frontal kicking strip for concrete installation, 1000mm PNC 206150
- Frontal kicking strip for concrete installation, 1200mm PNC 206151
- Frontal kicking strip for concrete installation, 1600mm PNC 206152
- Frontal kicking strip, 200mm (not for refr-freezer base) PNC 206174
- Frontal kicking strip, 400mm (not for refr-freezer base) PNC 206175
- Frontal kicking strip, 800mm (not for refr-freezer base) PNC 206176
- Frontal kicking strip, 1000mm (not for refr-freezer base) PNC 206177
- Frontal kicking strip, 1200mm (not for refr-freezer base) PNC 206178
- Frontal kicking strip, 1600mm (not for refr-freezer base) PNC 206179
- Kit 4 feet for concrete installation (not for 900 line free standing grill) PNC 206210
- Pair of side kicking strips PNC 206249
- Pair of side kicking strips for concrete installation PNC 206265
- Water column with swivel arm (water column extension not included) PNC 206289
- Water column extension for 700 line PNC 206291
- Chimney upstand, 400mm PNC 206303
- Right and left side handrails PNC 206307
- Flue condenser for 1/2 module, 120 mm diameter PNC 206310
- Energy saving device for pasta cookers PNC 206344
- Door for open base cupboard PNC 206350
- Automatic programmable basket lifting system for 24,5lt pasta cookers, 2 lifters PNC 206352
- Base support for feet or wheels - 400mm (700/900) PNC 206366
- Base support for feet or wheels - 800mm (700/900) PNC 206367
- Base support for feet or wheels - 1200mm (700/900) PNC 206368
- Base support for feet or wheels - 1600mm (700/900) PNC 206369
- Base support for feet or wheels - 2000mm (700/900) PNC 206370
- Rear paneling - 600mm (700/900XP) PNC 206373
- Rear paneling - 800mm (700/900) PNC 206374
- Rear paneling - 1000mm (700/900) PNC 206375
- Rear paneling - 1200mm (700/900) PNC 206376
- 6 baskets (105x105) for pasta cookers - 700XP PNC 206397
- Chimney grid net, 400mm PNC 206400
- 2 side covering panels for free standing appliances PNC 216000
- Frontal handrail, 400mm PNC 216046
- Frontal handrail, 800mm PNC 216047
- Frontal handrail, 1200mm PNC 216049
- Frontal handrail, 1600mm PNC 216050
- Large handrail - portioning shelf, 400mm PNC 216185
- Large handrail - portioning shelf, 800mm PNC 216186
- Support frame for 4 baskets for 24,5lt pasta cookers PNC 921606
- Lid for 24,5lt pasta cookers PNC 921607
- 2 half size baskets 170x220 for 24,5lt pasta cookers PNC 921610
- Full size basket for 24,5lt pasta cookers PNC 921611
- 4 baskets 105x160 for 24,5lt pasta cookers (921606 must be ordered together) PNC 921618
- 2 half size baskets 105x350 for pasta cookers for 24,5lt pasta cookers PNC 921619
- Pressure regulator for gas units PNC 927225



**Modular Cooking Range Line
700XP Freestanding Gas Pasta Cooker, 1 Well 24.5 litres**

The company reserves the right to make modifications to the products without prior notice. All information correct at time of printing.



Electrolux

Modular Cooking Range Line 700XP Freestanding Gas Pasta Cooker, 1 Well 24.5 litres

Front

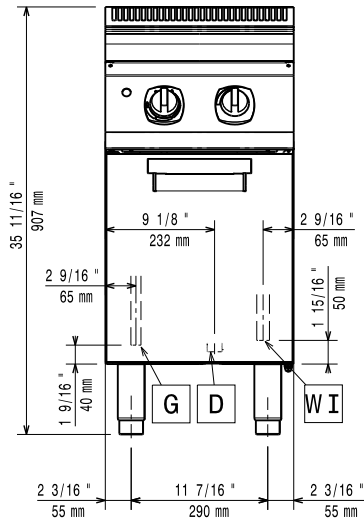

Top

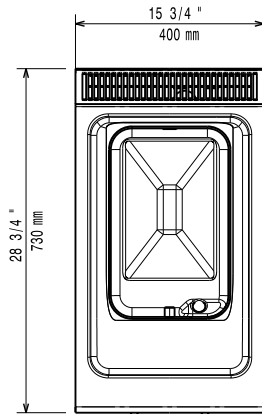

- D = Drain
- G = Gas connection
- WI = Water inlet

Side

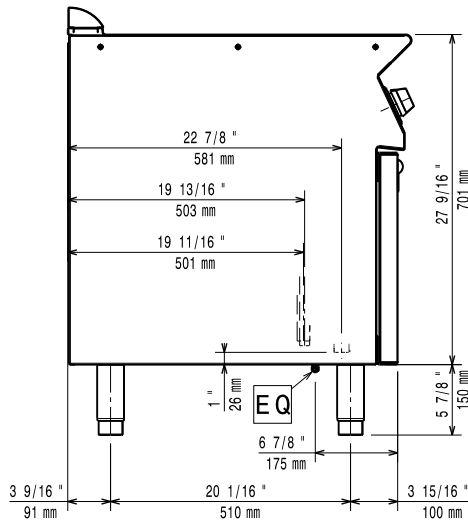

Gas

Gas Power:

371090 (E7PCGD1KF0) 35794.5 Btu/hr (10.5 kW)

Gas Type Option:

LPG

Gas Inlet:

1/2"

Natural gas - Pressure:

7" w.c. (17.4 mbar)

LPG Gas Pressure:

11" w.c. (27.7 mbar)

Water:

Drain "D":

1"

Incoming Cold Water line size:

1/2"

Total hardness:

5-50 ppm

Electrolux recommends the use of treated water, based on testing of specific water conditions.

Please refer to user manual for detailed water quality information.

Key Information:

| | |
|---|---------------------|
| Usable well dimensions (width): | 250 mm |
| Usable well dimensions (height): | 300 mm |
| Usable well dimensions (depth): | 400 mm |
| Well Capacity (MAX): | 24.5 lt MAX |
| Net weight: | 50 kg |
| Shipping weight: | 50 kg |
| Shipping height: | 1140 mm |
| Shipping width: | 460 mm |
| Shipping depth: | 820 mm |
| Shipping volume: | 0.43 m ³ |

If appliance is set up or next to or against temperature sensitive furniture or similar, a safety gap of approximately 150 mm should be maintained or some form of heat insulation fitted.

Modular Cooking Range Line
700XP Freestanding Gas Pasta Cooker, 1 Well 24.5 litres

The company reserves the right to make modifications to the products without prior notice. All information correct at time of printing.

